

bZ4X

Front & rear set mudflaps

Installation Instructions

Model year: As from 2022/03

Vehicle code: X***0*_***M**/ X***0*_***P**/ X***0*_***H**
Y***5*_***M**/ Y***5*_***P**/ Y***5*_***H**

Part number: PW389-42000

Manual reference number: AIM 005 175-0

Latest Version
CLICK HERE



Revision Record







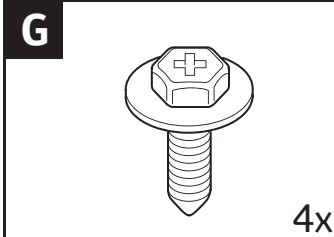
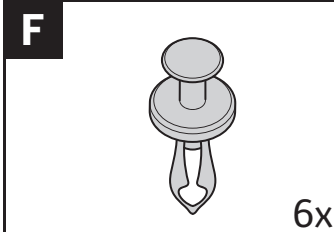
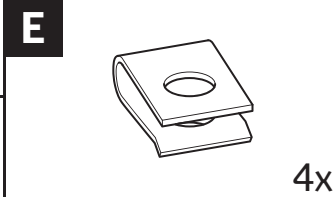
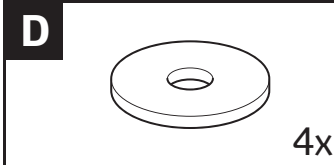
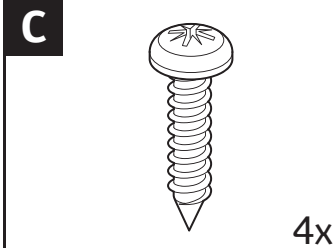
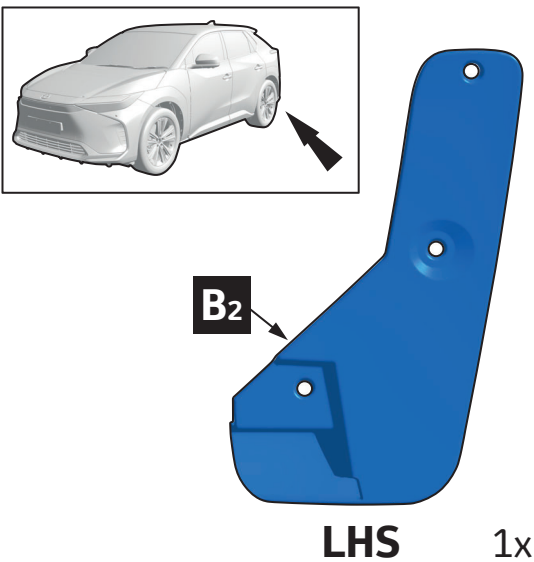
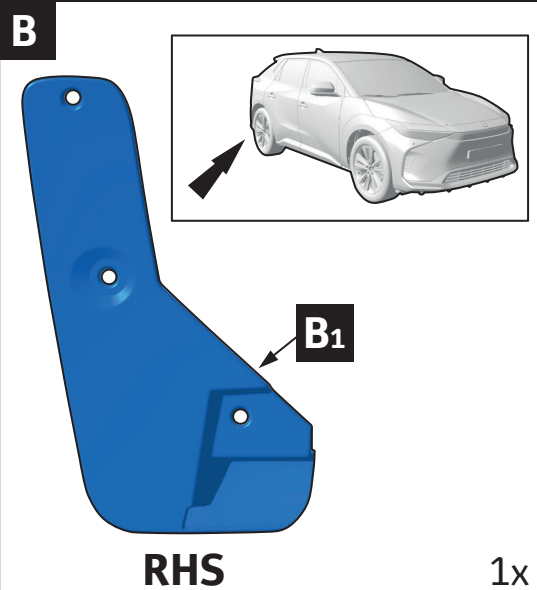
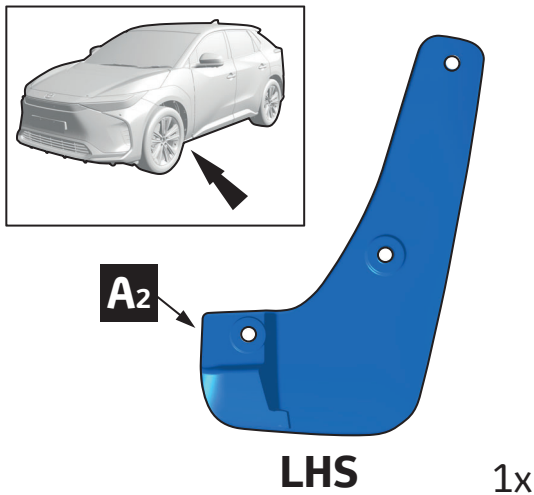
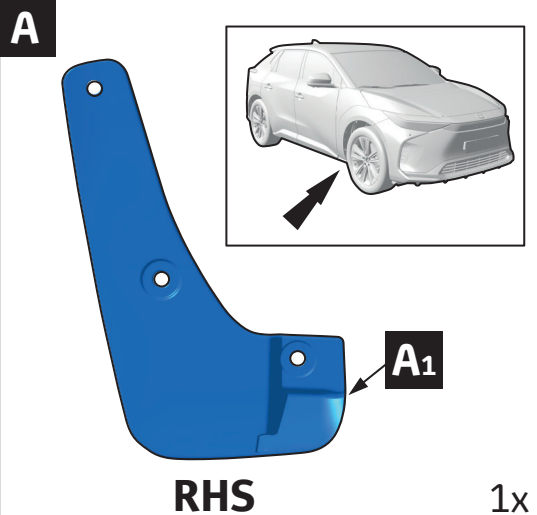

Rev. No.	Date	Page	Step	Remarks

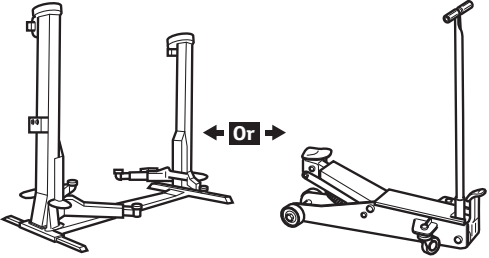
KIT CONTENT

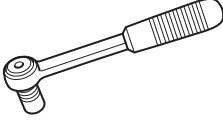
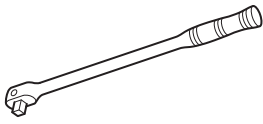
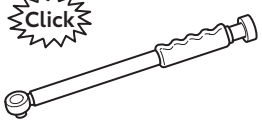

PW389-42000

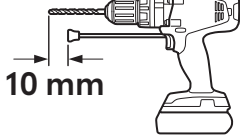
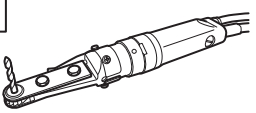
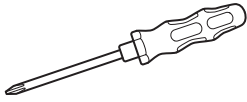
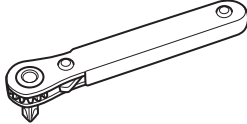

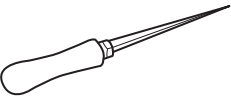
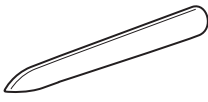
TOOLS

			10 mm 17 mm		17 mm		10 mm 17 mm
							
Cobalt Drill bits Ø3 mm Ø6 mm	Cobalt Drill bits Ø3 mm Ø6 mm		PH2		PH2	Torque stick 100Nm	
	OR 						
							

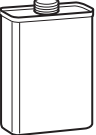



CONSUMABLES

CLEANER / DEGREASER							
							
	AIM 003 516-*						

PERSONAL PROTECTION EQUIPMENT

							
---	--	--	--	--	--	--	--

INFO

			
Material Safety Data Sheet		Technical Data Sheet	

INSTALLATION INSTRUCTIONS



ALTERNATE

1

STANDARD

5

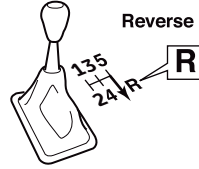

1

2

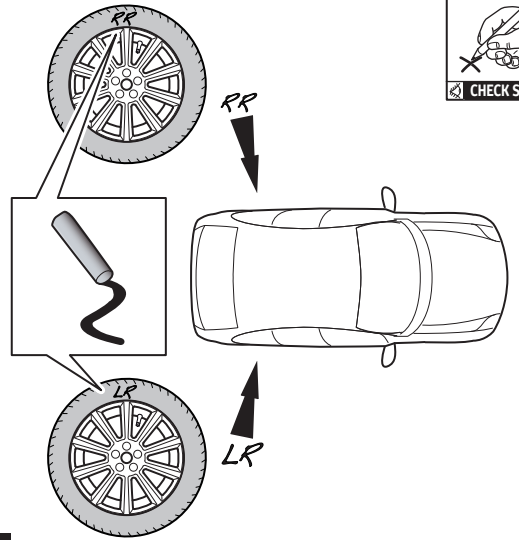

3

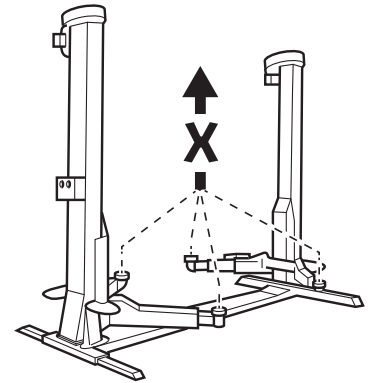
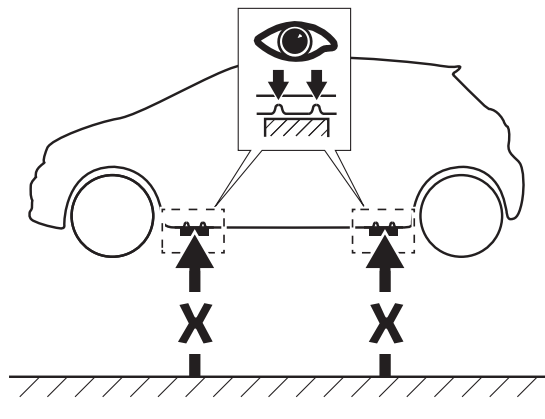
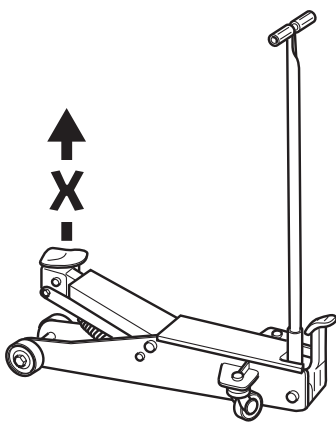

4

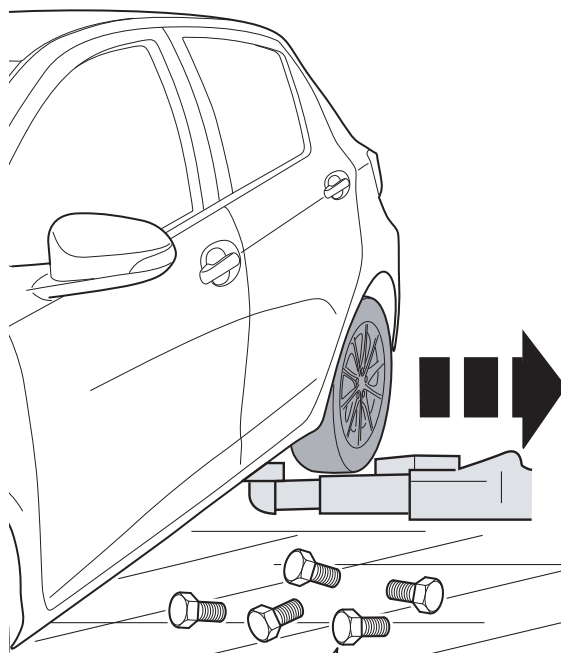

5x Y1



17 mm

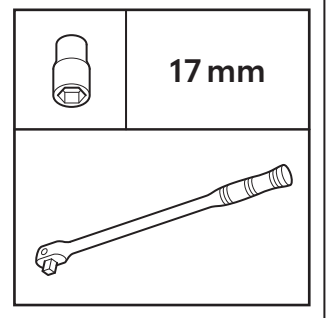

17 mm

LHS = RHS

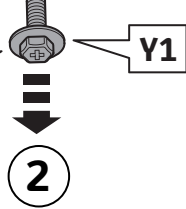
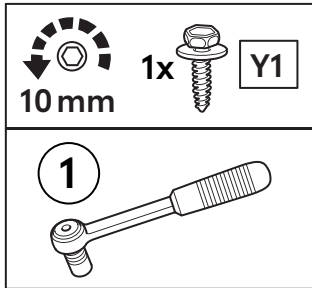
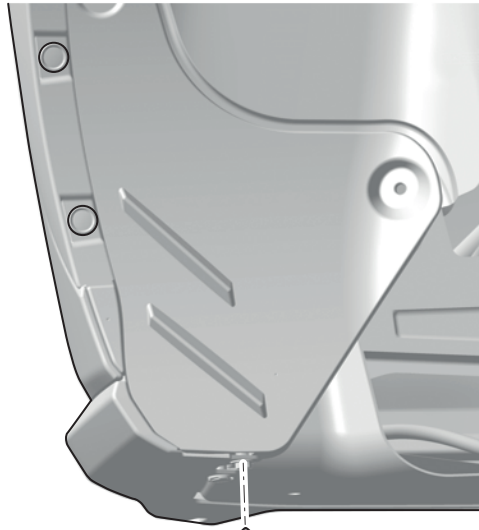
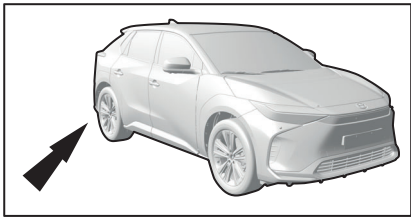

5

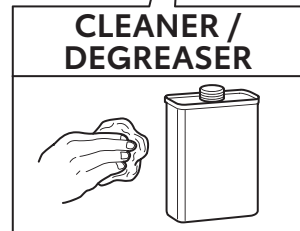
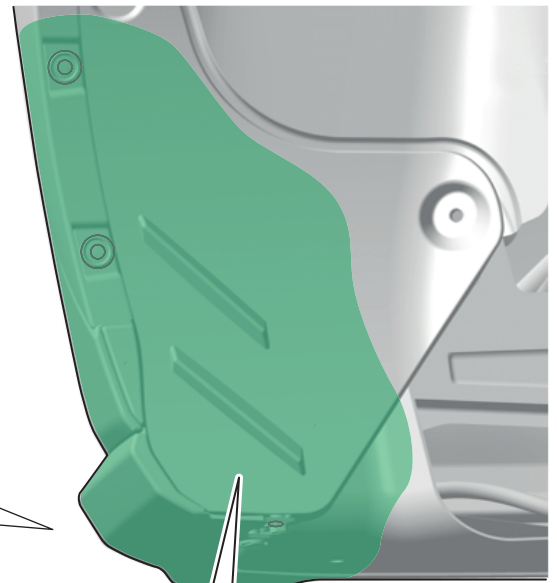
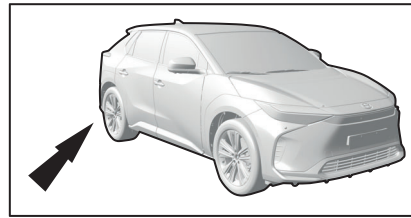

6

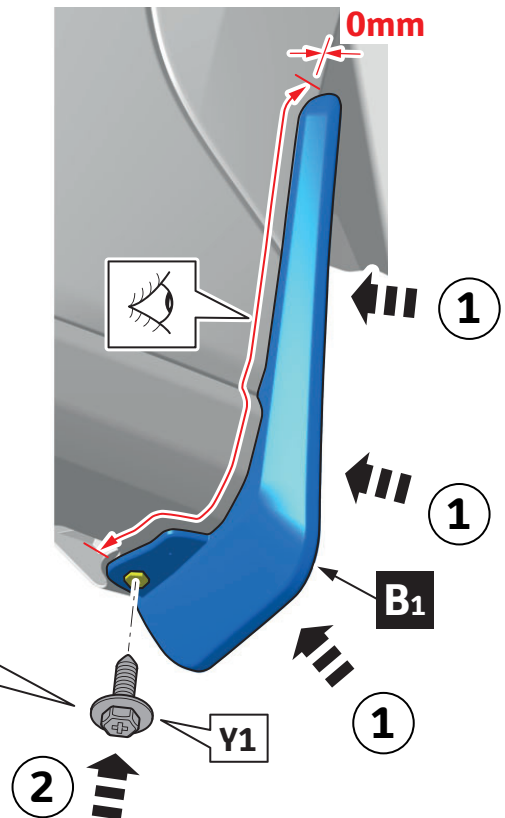
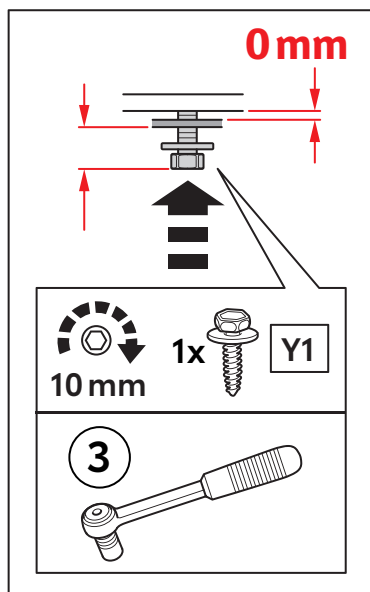
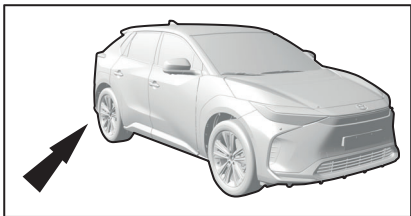

7

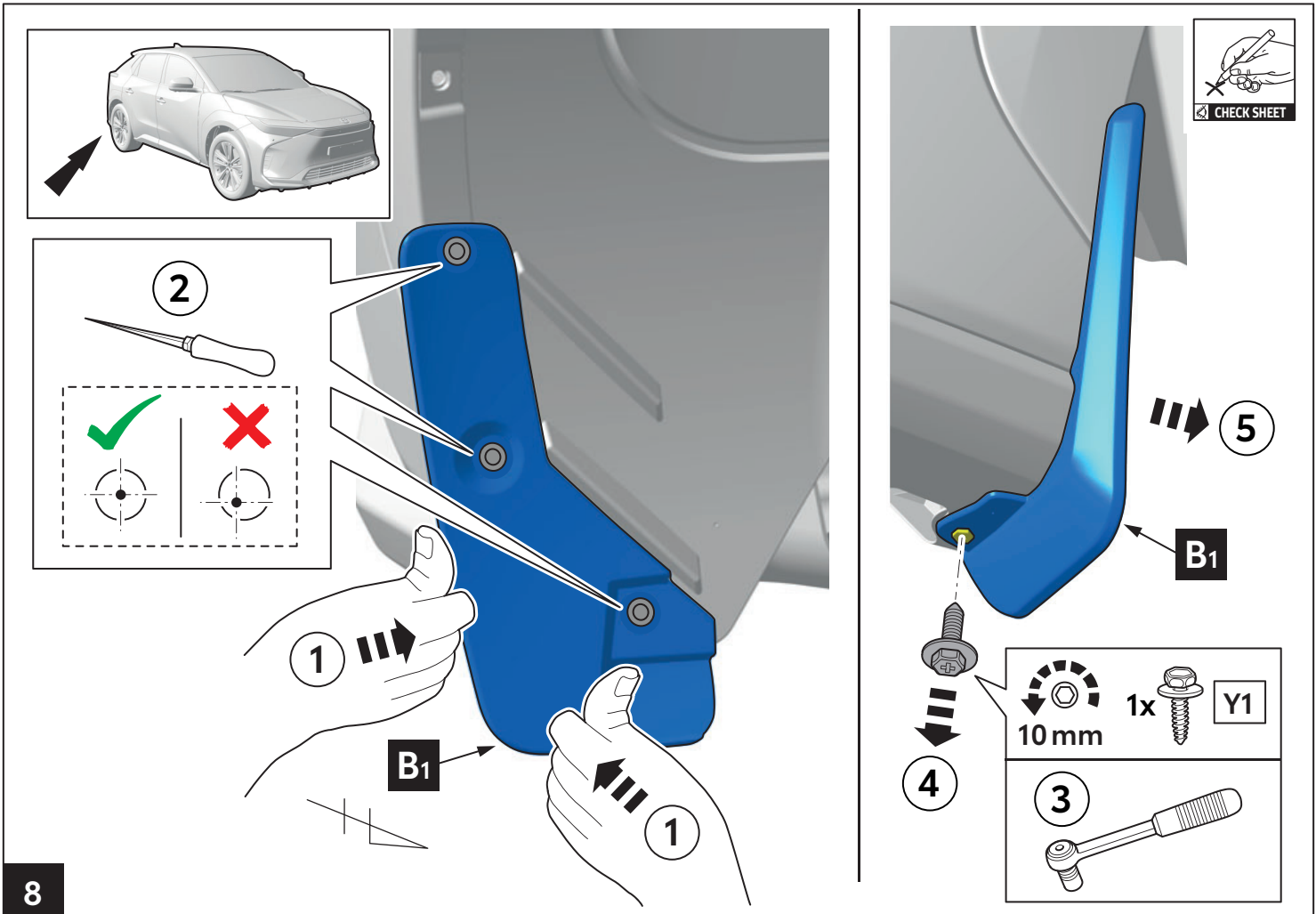

8

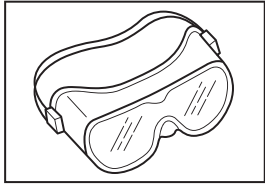
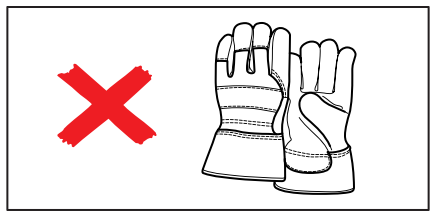

ALTERNATE METHOD	STANDARD METHOD
Cobalt Drill bits Ø3 mm Ø6 mm	Cobalt Drill bits Ø3 mm Ø6 mm
 10 mm	OR

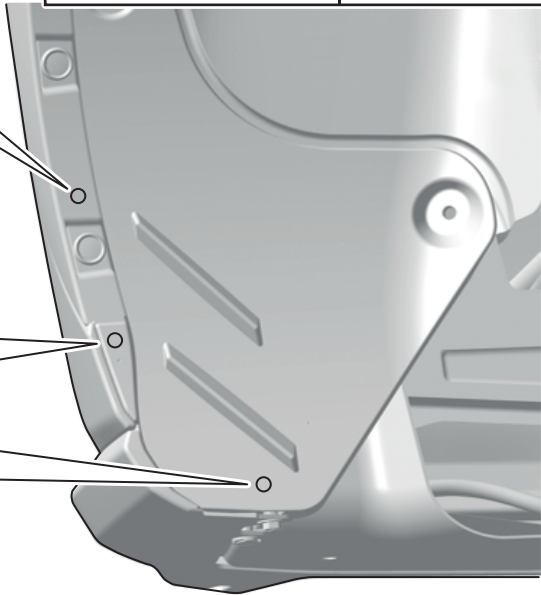
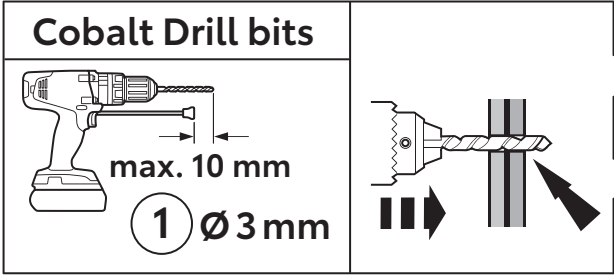
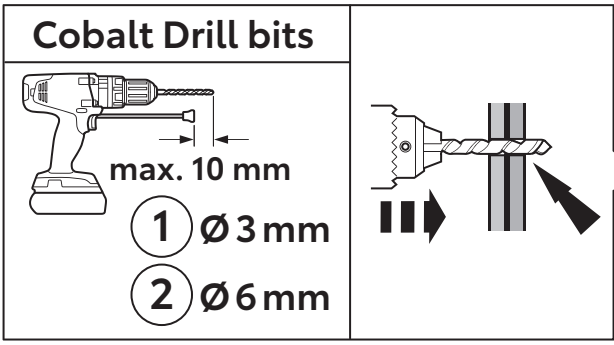

9

10

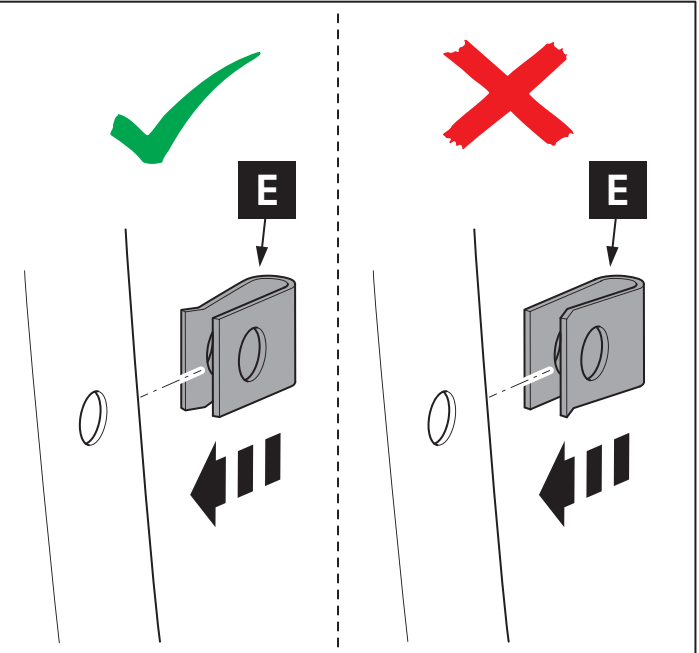
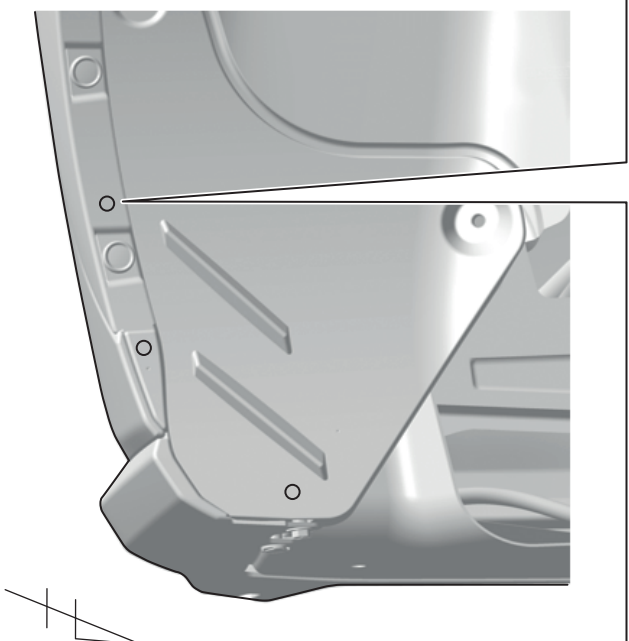

11

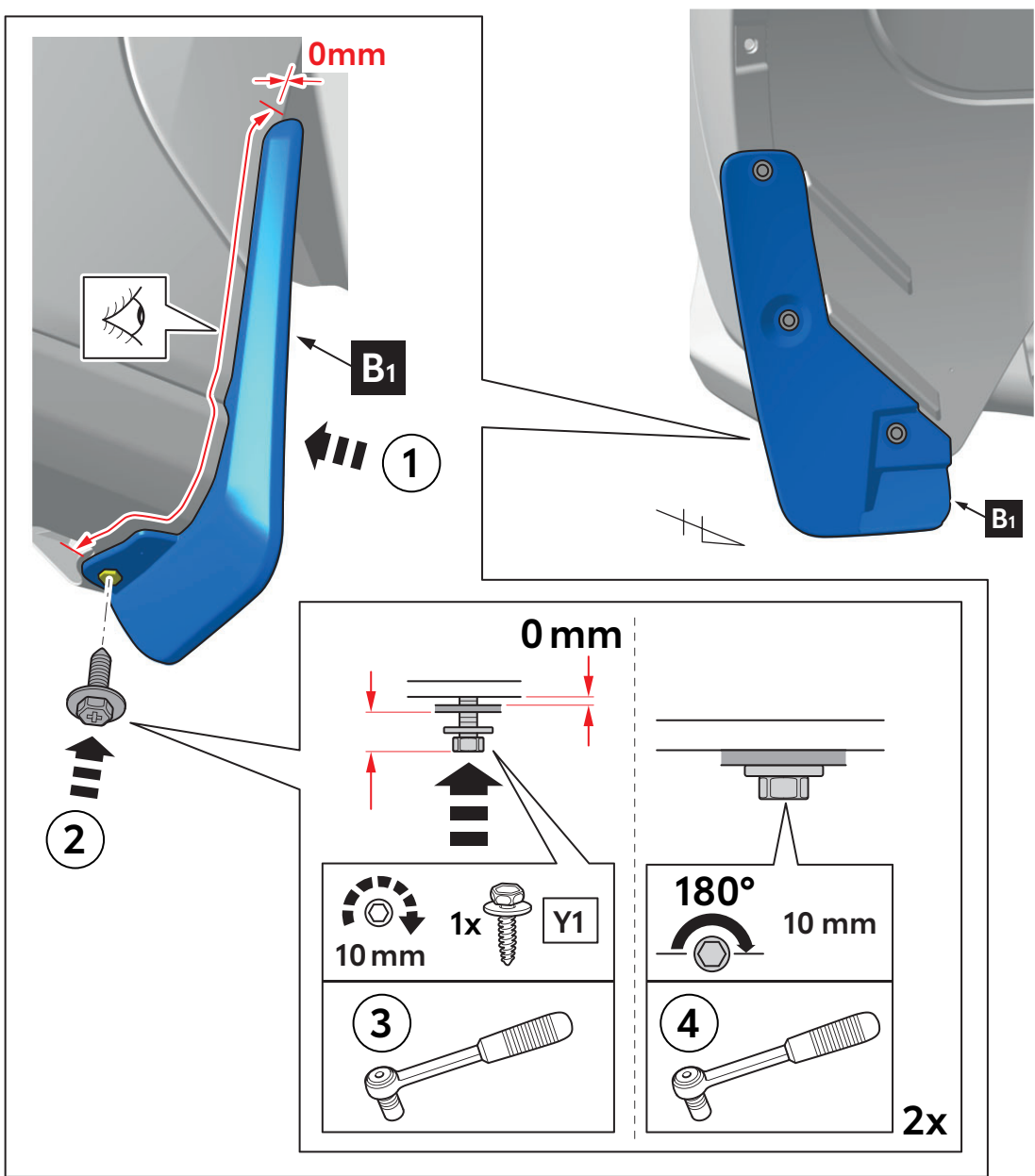

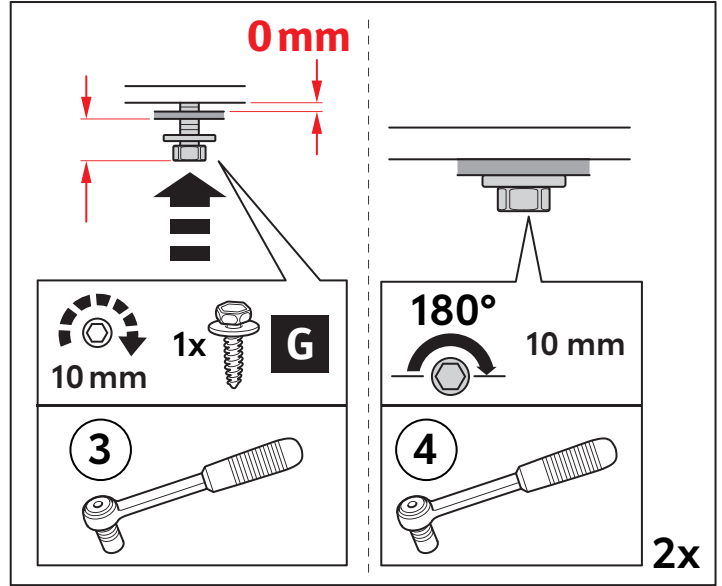
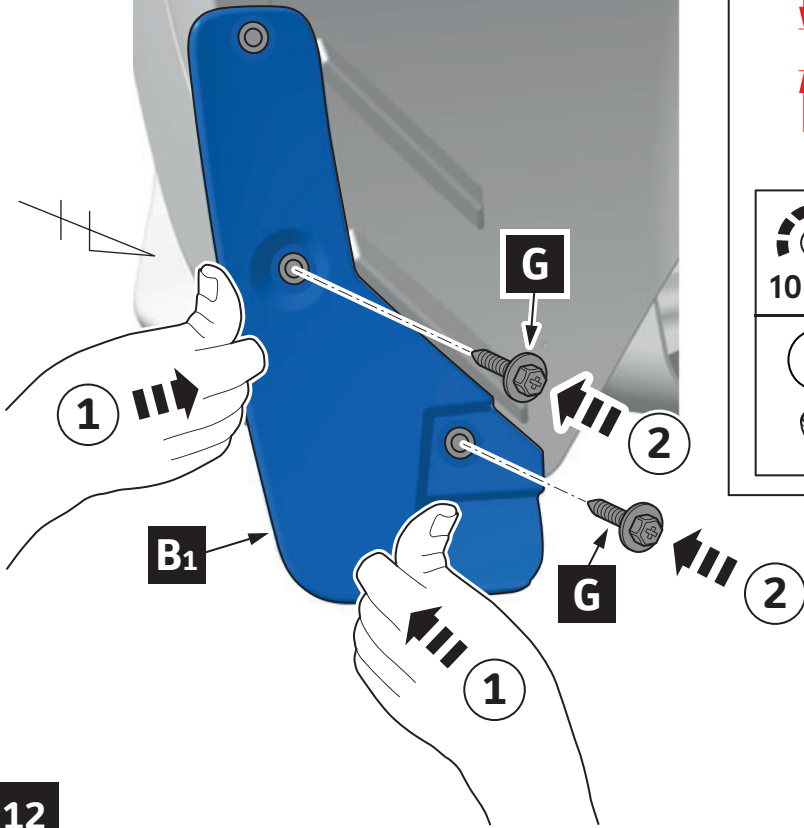
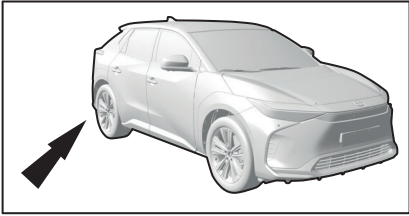

12

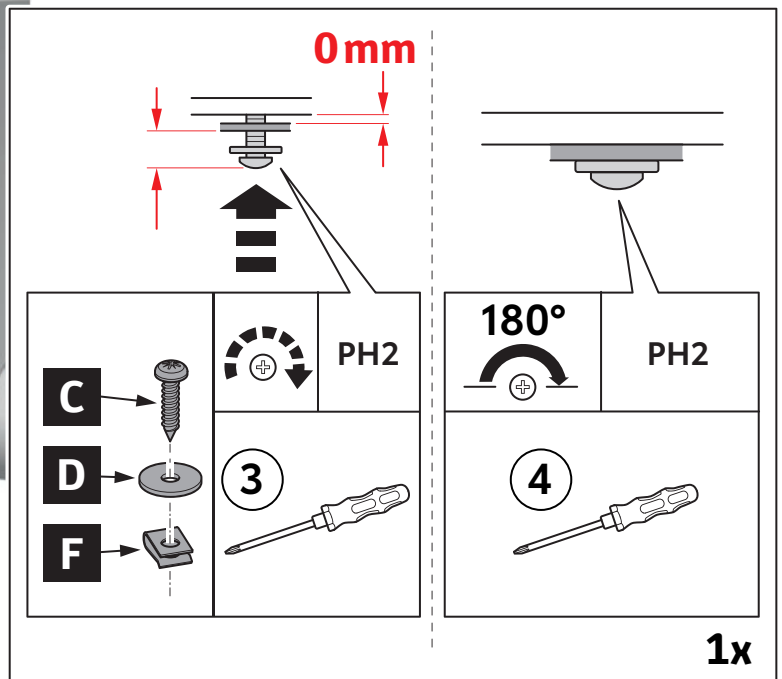
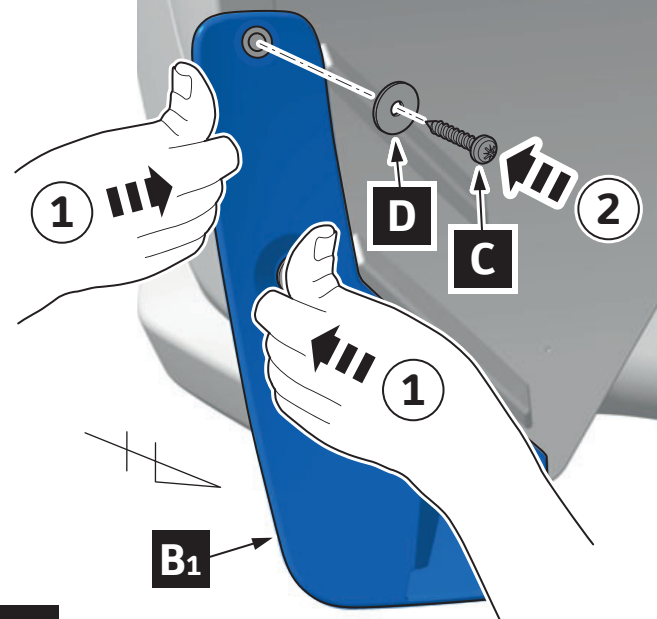
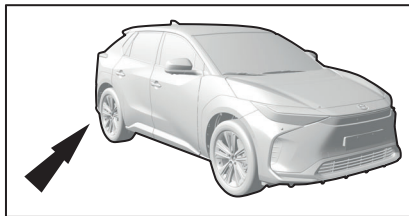

13

INFO



RHS

=

LHS

ALTERNATE

III → **14**

STANDARD

III → **17**

17 mm

5x Y1 **4**

1

17 mm
Torque stick 100Nm **2**

1 2 3 4 5

14

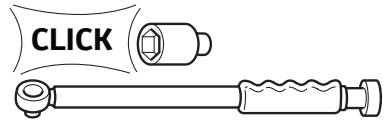
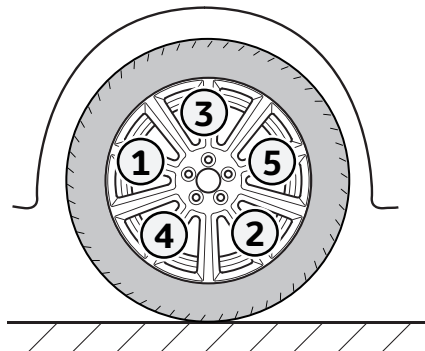
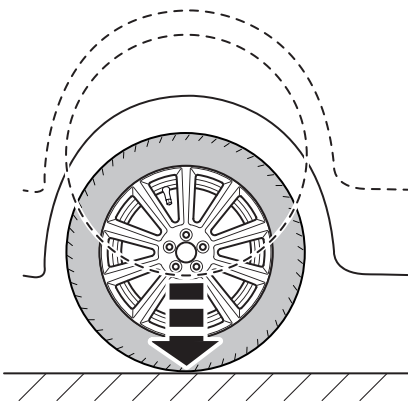

?? Nm
see AIM 004 425-*

15

16

RHS

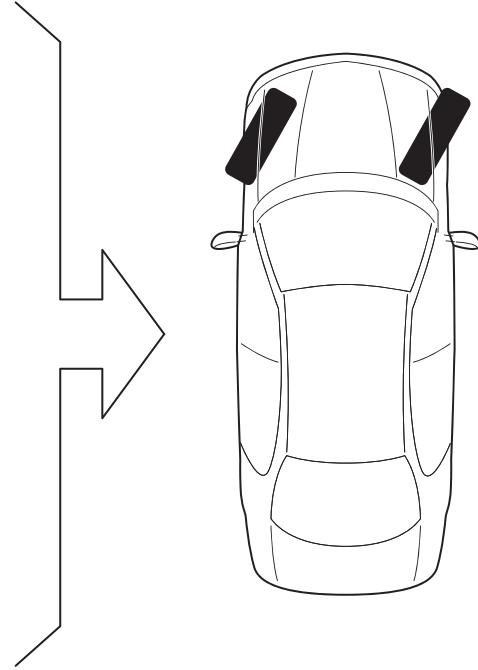
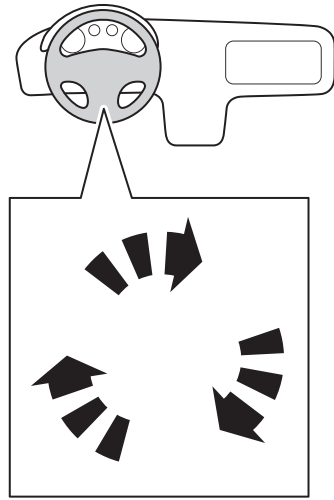

17

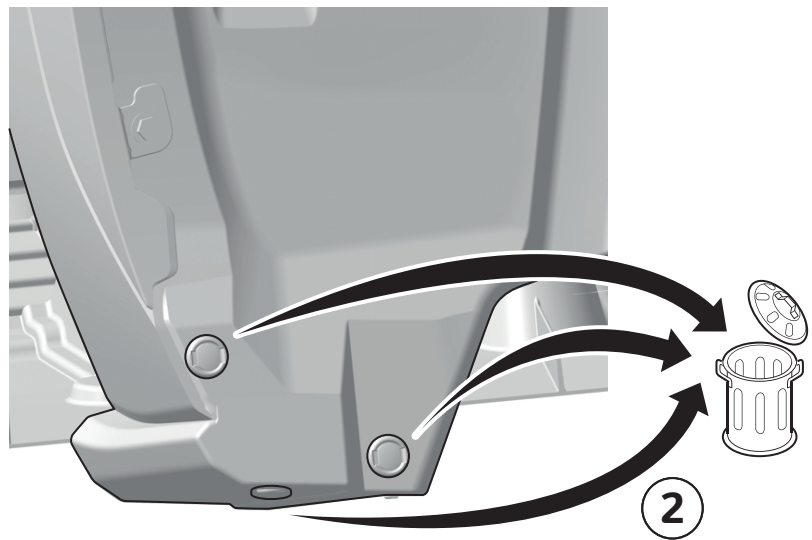
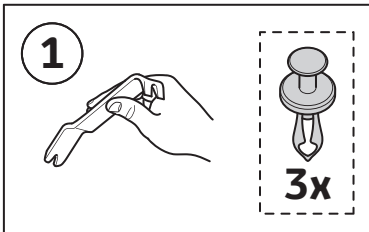
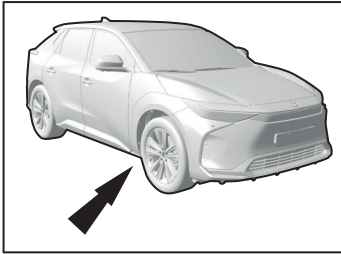

18

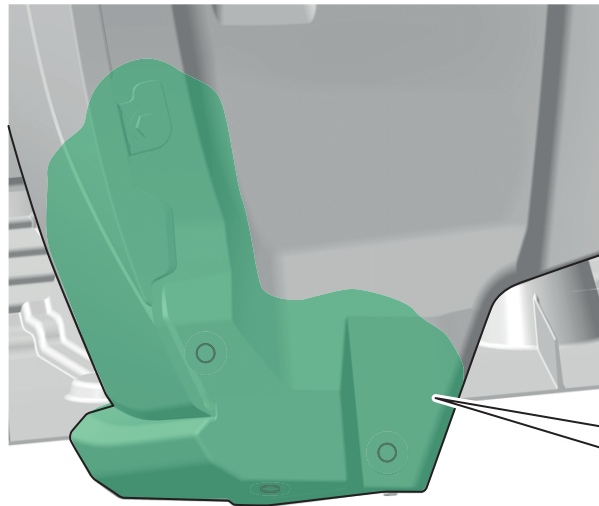
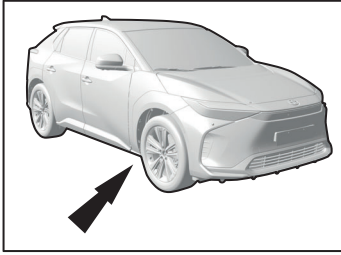

19

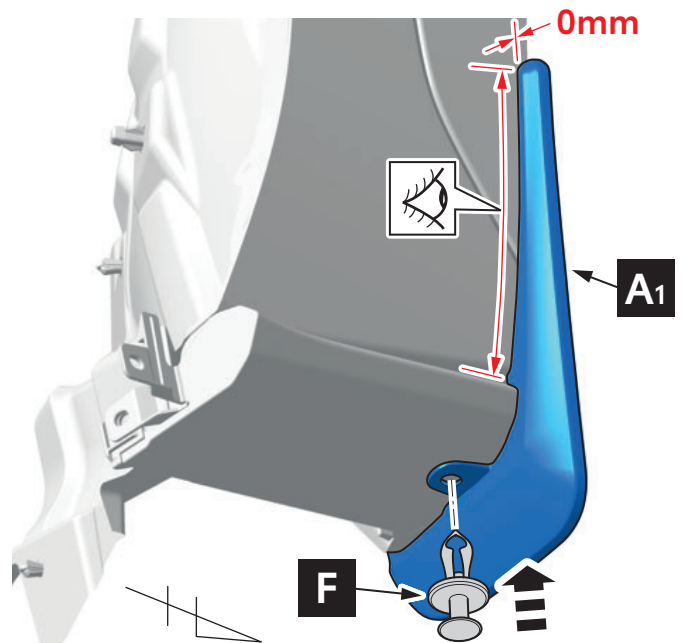
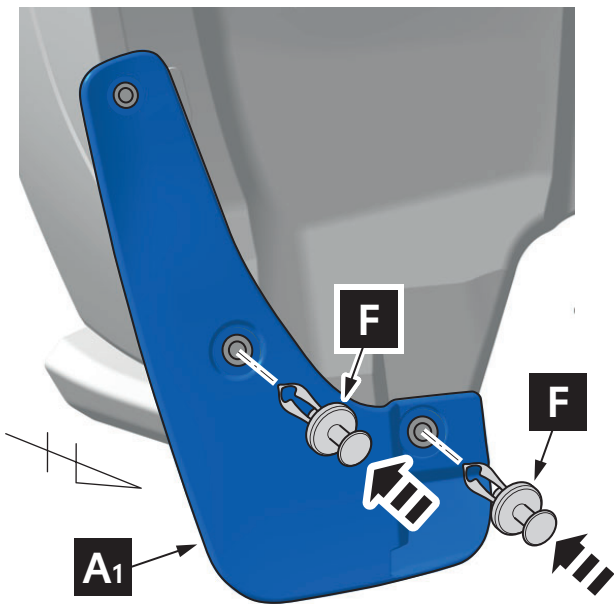
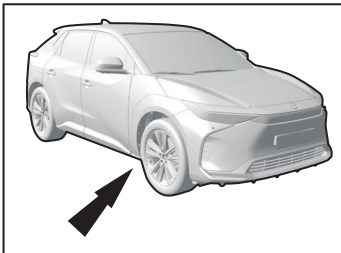

20

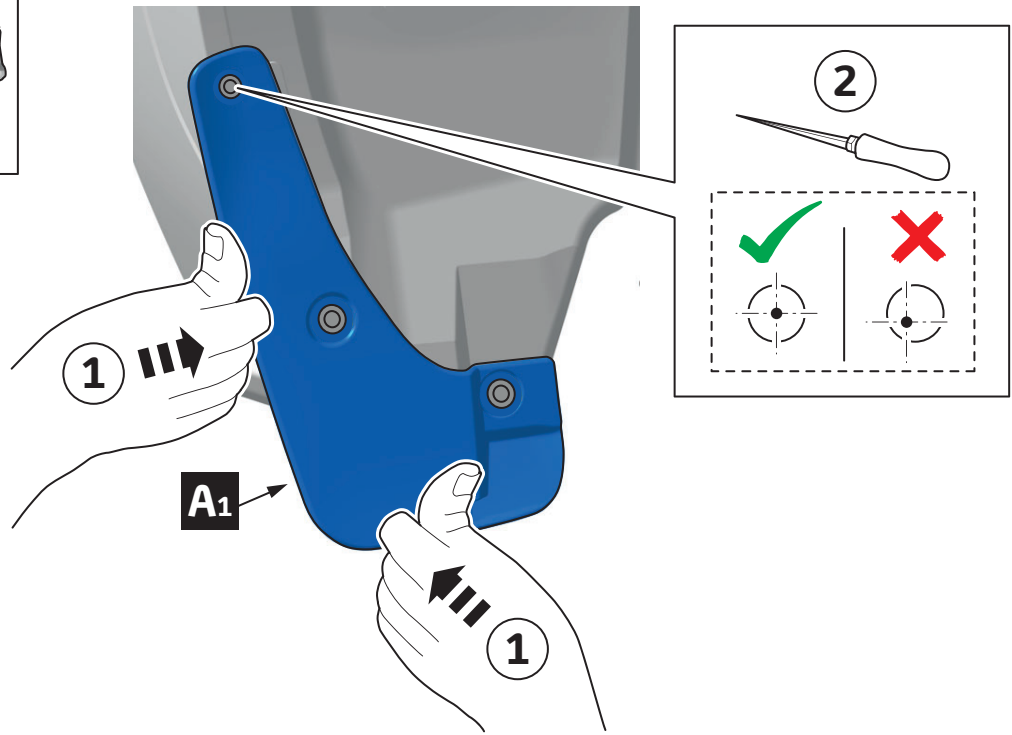
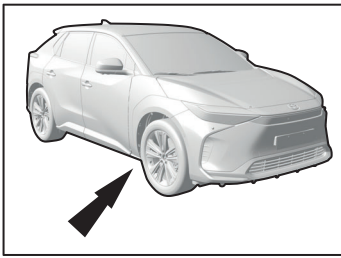

21

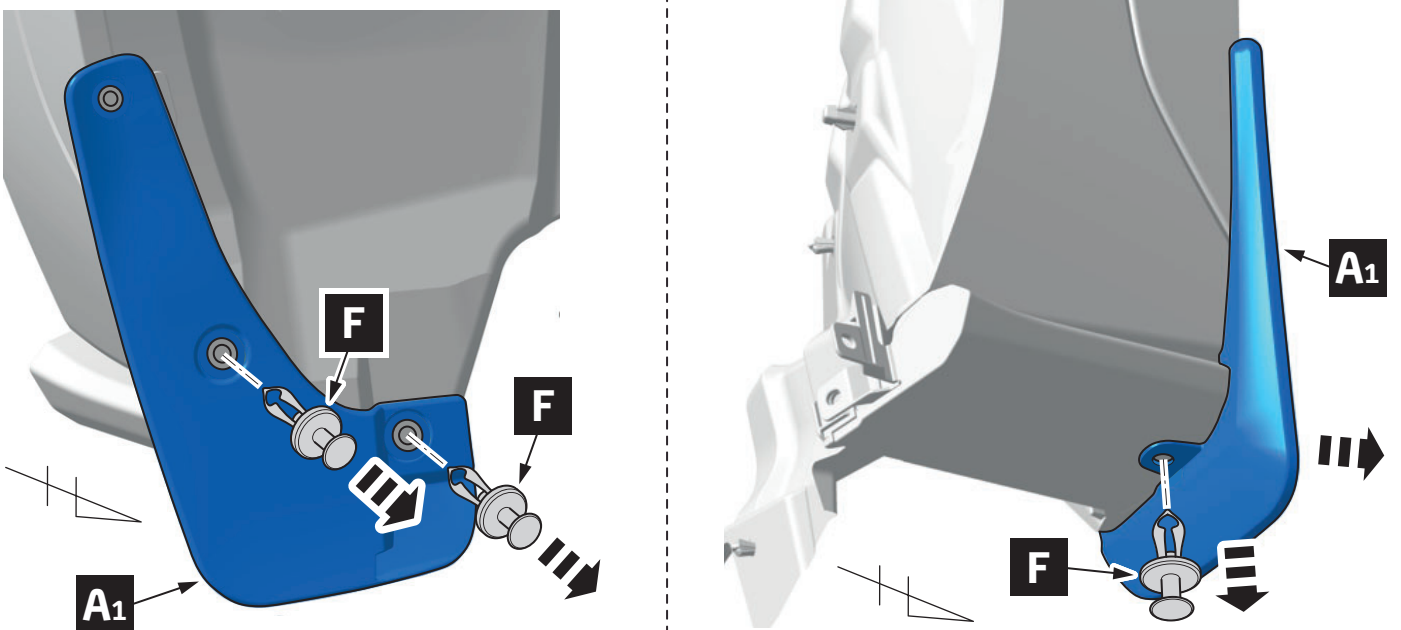
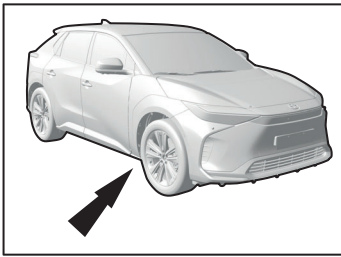

22

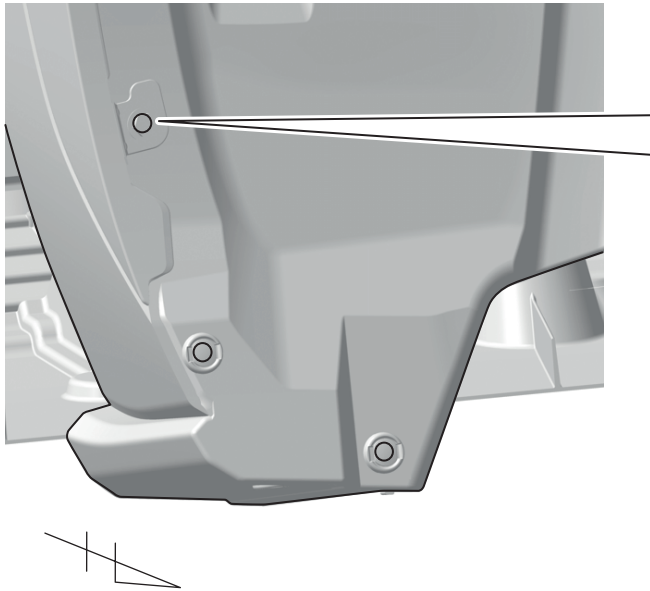
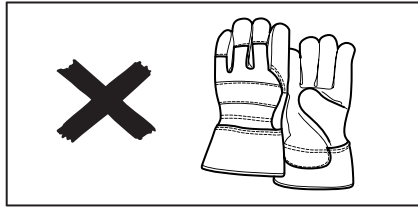
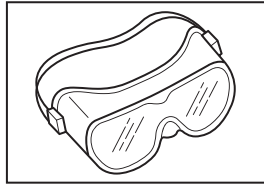
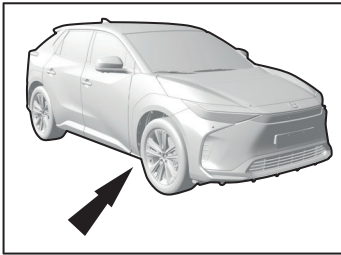

ALTERNATE METHOD

Cobalt Drill bits

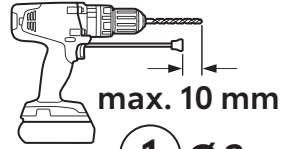

- 1 Ø3 mm
- 2 Ø6 mm

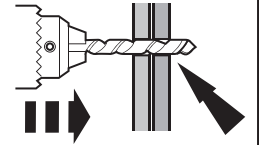

STANDARD METHOD

Cobalt Drill bits

- 1 Ø3 mm
- 2 Ø6 mm

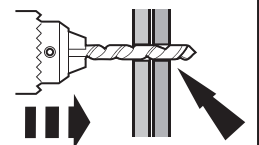
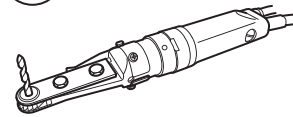

23

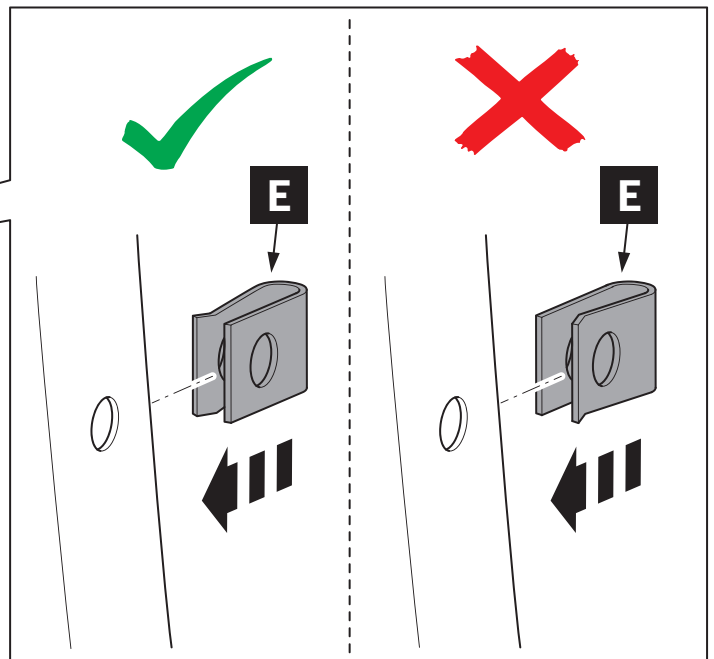
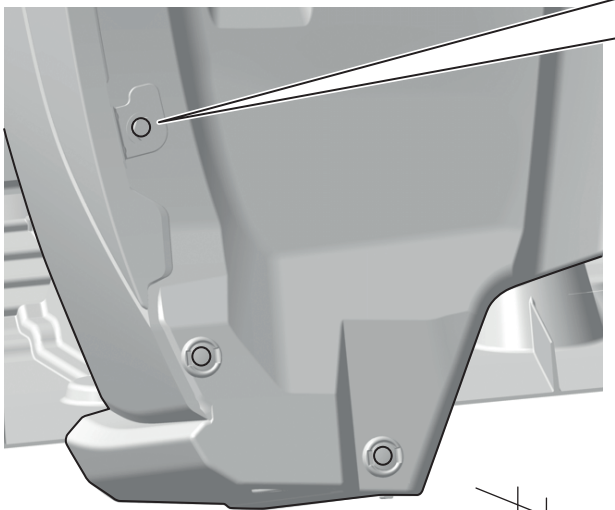
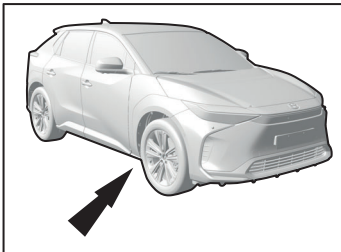

24

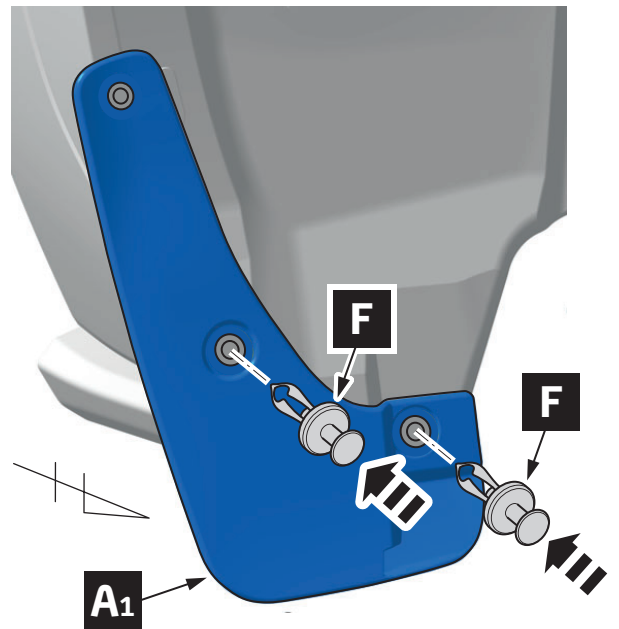
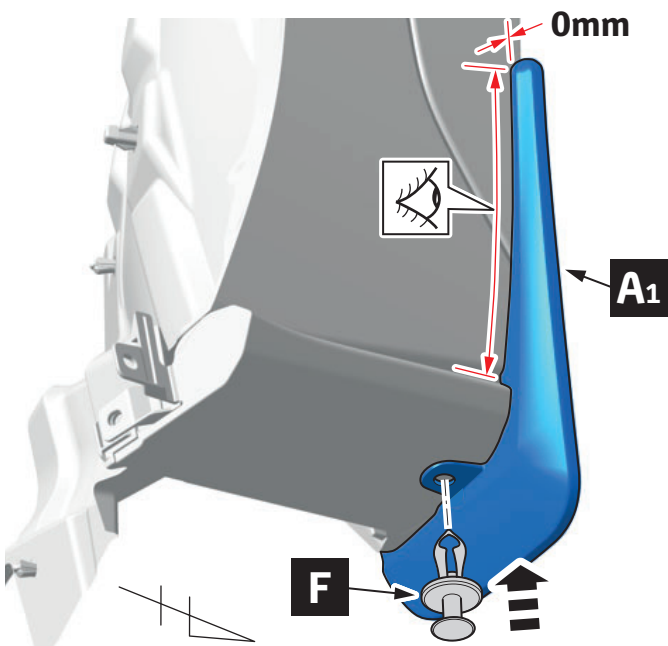
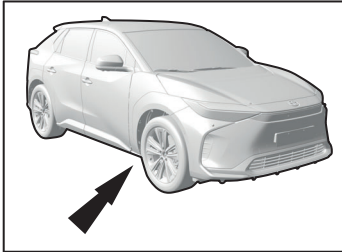

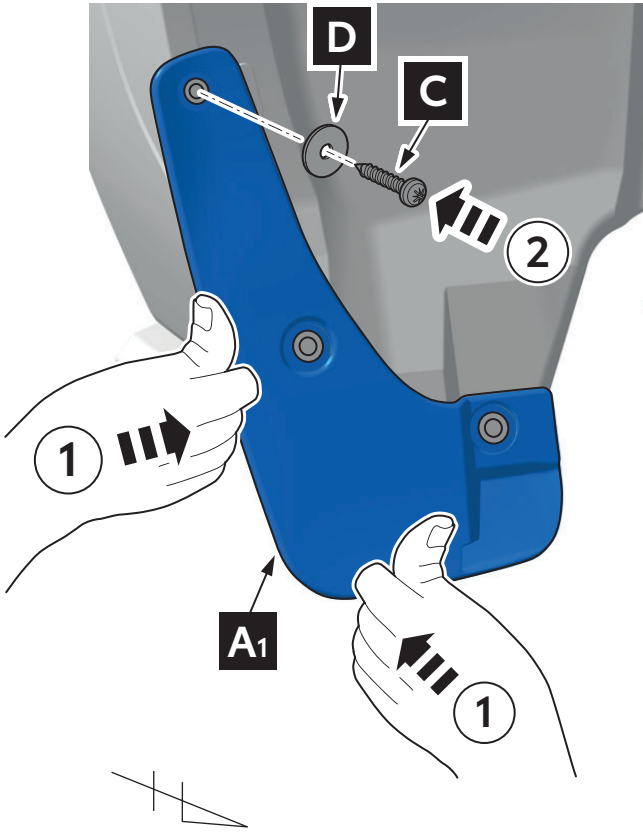
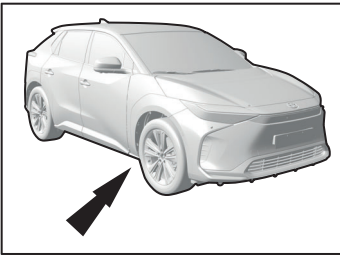

ALTERNATE

0 mm

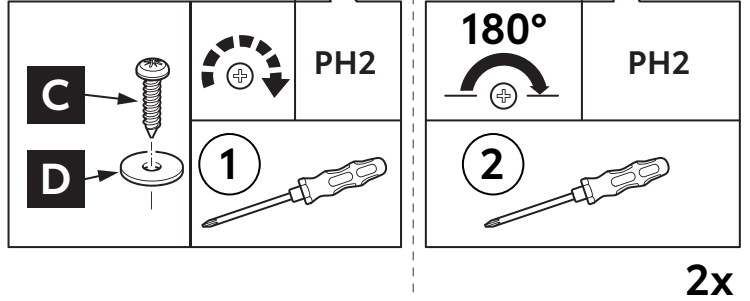

STANDARD

0 mm

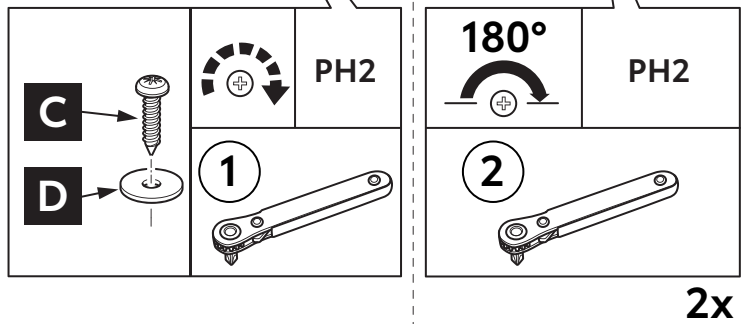

26

INFO

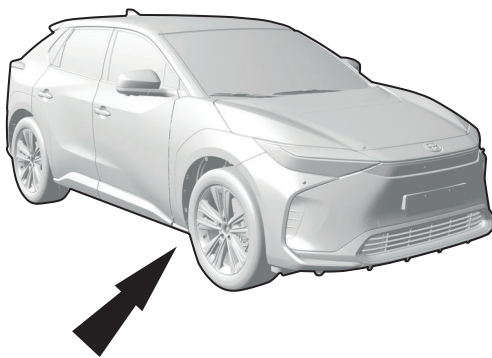

RHS

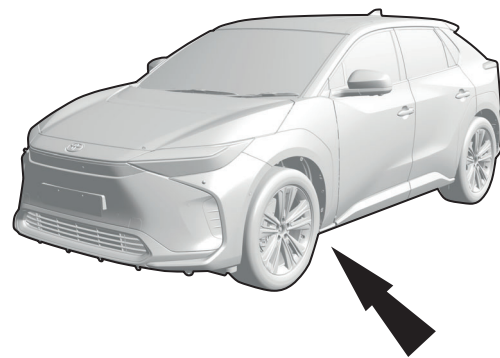

LHS

=

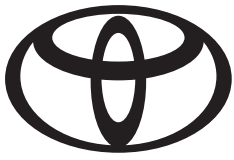

CHECK SHEET

Page 1 of 3

Model/Year **bZ4X**
As from 2022/03

Front & rear set mudflaps

VINn°

DURING INSTALLATION

1

= OK
P/N = OK

=A =B

2

Serial Number

Click

?? Nm
see AIM 004 425-*

A B

3

RR = RR = OK

LR = LR = OK

A B

AFTER INSTALLATION

1

RHS

LHS

C

D

E

1x

= OK

RHS

LHS

AFTER INSTALLATION

RHS

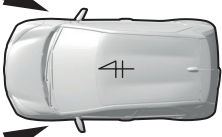

LHS



2

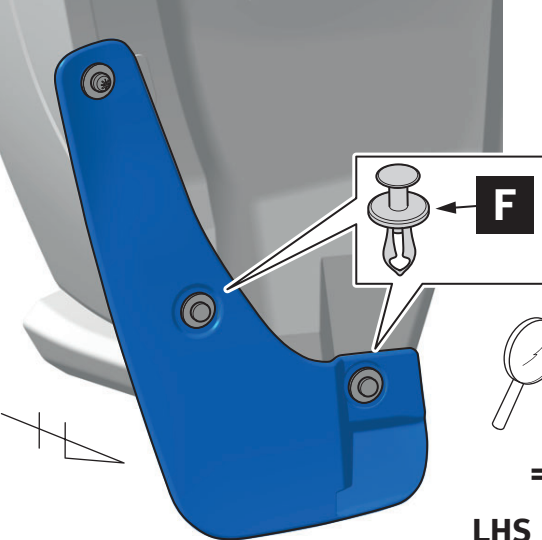

= OK

LHS	RHS
<input type="checkbox"/>	<input type="checkbox"/>

= OK

LHS	RHS
<input type="checkbox"/>	<input type="checkbox"/>

RHS

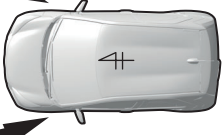

LHS

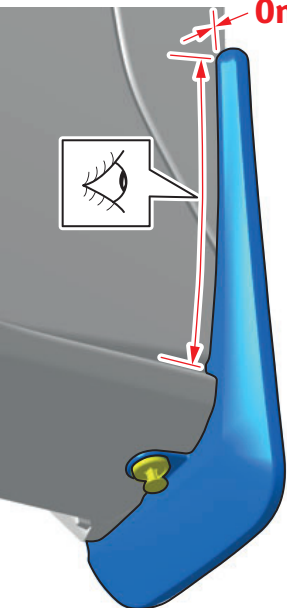

3

= OK

LHS	RHS
<input type="checkbox"/>	<input type="checkbox"/>

RHS

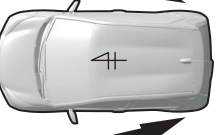

LHS

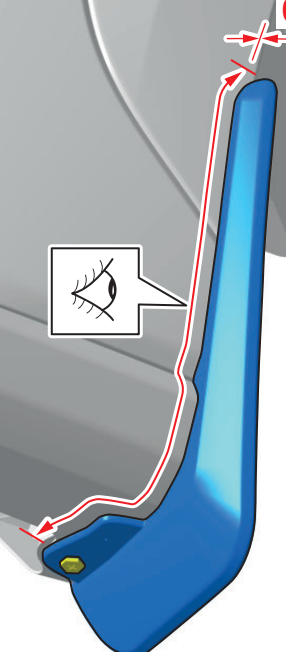

4

= OK

LHS	RHS
<input type="checkbox"/>	<input type="checkbox"/>

AFTER INSTALLATION

RHS

LHS

Y1
1x

✗	✓

5

RHS

LHS

C		
	✗	✓

G		
	✗	✓

C	
D	
E	
	1x

G	
	2x

RHS

LHS

6

= OK

7

Installation Date: .. / .. /	Technician Name & Signature:	Stamp:
--	---	---------------