

8 Install the 2 clips A  
Die 2 federmutter A befestigen  
Installer les 2 clips A  
Bevestiging de 2 opschuflmoeren A

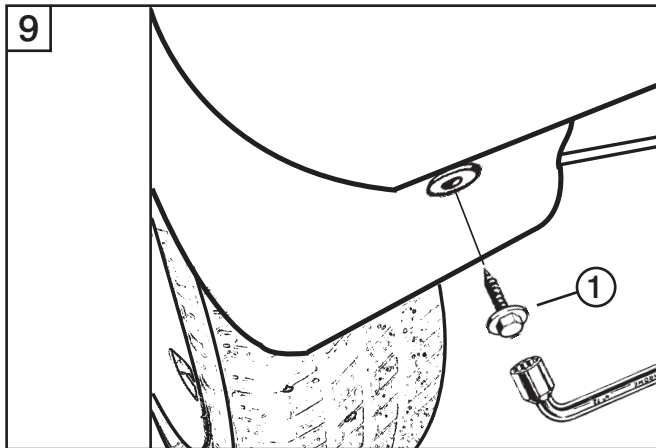

9 Install the screws 1  
Schrauben 1 befestigen  
Visser la vis 1  
Schroeven 1 installeren

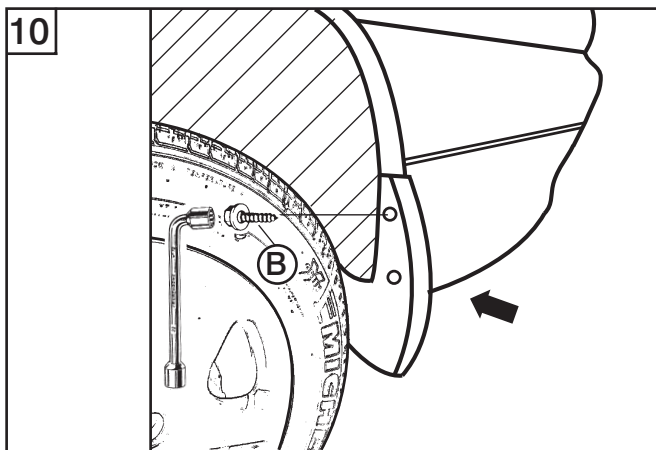

10 Push against the mudflap so that it follows the body contour.  
Den schmutzfänger an das fahrzeug entsprechend der kontour andrücken.  
Pousser la bavette contre l'aile comme indiqué.  
Druk zodanig tegen de mudflap dat hij de contour van het voertuig volgt.

Install the screws B  
Schrauben B befestigen  
Visser la vis B  
Schroeven B installeren

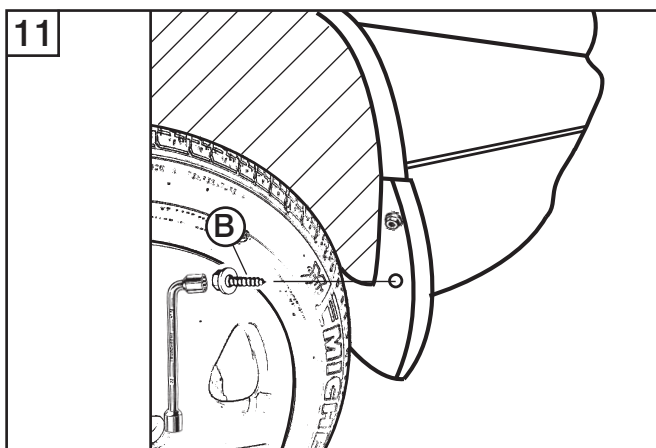

11 Install the screws B  
Schrauben B befestigen  
Visser la vis B  
Schroeven B installeren



# TOYOTA

## AVENSIS

ALL

PARTNUMBER : PZ 416 - T9960 - 00

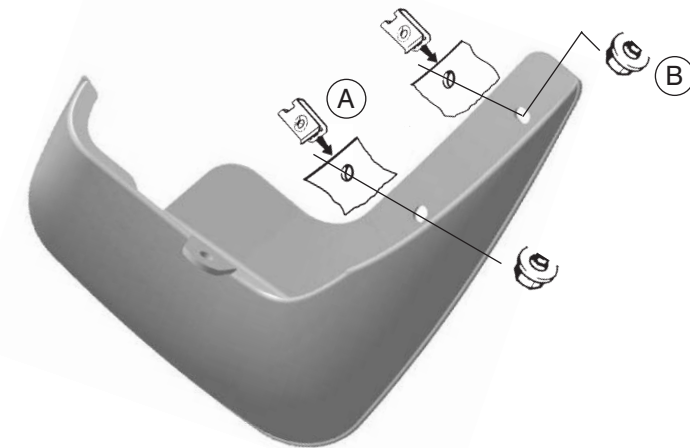

REAR MUDFLAPS  
SCHMUTZFÄNGER HINTEN  
ACHTERSTE SPATSCHERMEN  
BAVETTES ARRIERES

KIT CONTENT - STÜCKLISTE - CONTENU - KIT INHOUD

1 x REAR MUDFLAP LHS  
1 x REAR MUDFLAP RHS  
4 x NUT SPRING : Réf. 2204  
4 x SCREW WITH WASHER Ø 5,5 x 16

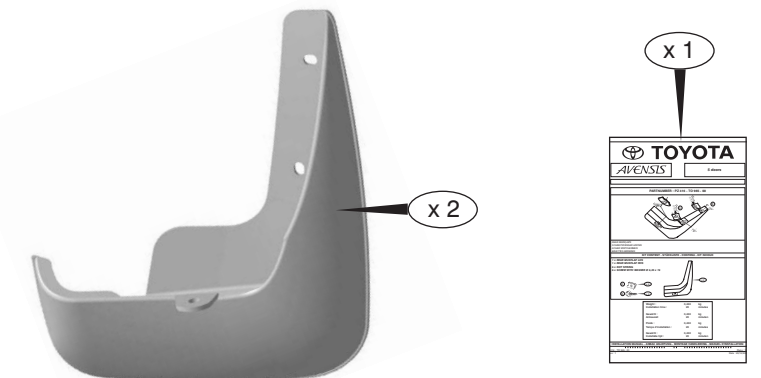
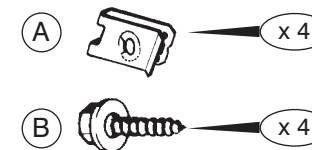

Weight :	0,295	kg
Installation time :	15	minutes
Gewicht :	0,295	kg
Anbauzeit	15	minuten
Poids :	0,295	kg
Temps d'installation :	15	minutes
Gewicht :	0,295	kg
Installatie tijd :	15	minuten

INSTALLATION MANUAL - ANBAU ANLEITUNG - MONTAGE HANDLEIDING - MANUEL D'INSTALLATION

PZ 416 - T9960 - 00

Issue : 2

Page : 1/4

Date : 08/12/2002

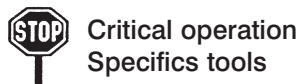

Critical operation  
Specifics tools



Operator safety



Check point

Page : 4/4

Date : 08/12/2002

PARTNAME : REAR MUDFLAPS      PARTNUMBER : PZ 416 - T9960 - 00

APPLICATION / ANWENDUNG / APPLICATIE

MODEL CODE : \*\*T25\*\* - A\*\*\*W

☺ VEHICULE OPTION / FAHRZEUG OPTION / OPTION VEHICULE / VOERTUIG OPTIE ☹	
1	1
2	2
3	3
4	4
5	5
6	6
7	7
8	8
9	9
10	10

ACCESSORY / ZUBEHÖR / ACCESSOIRE	
1	1
2	2
3	3
4	4
5	5
6	6
7	7
8	8
9	9
10	10

SAFETY PRECAUTION / SICHERHEITSMASSNAHME / PRECAUTIONS DE SECURITE / VEILIGHEIDVOORZIENINGEN

Step/Punkt/Point/Stap	Step/Punkt/Point/Stap
-----------------------	-----------------------

Step/Punkt/Point/Stap	Step/Punkt/Point/Stap
-----------------------	-----------------------

TOOLS / WERKZEUGE / OUTILS / WERKTUIGEN

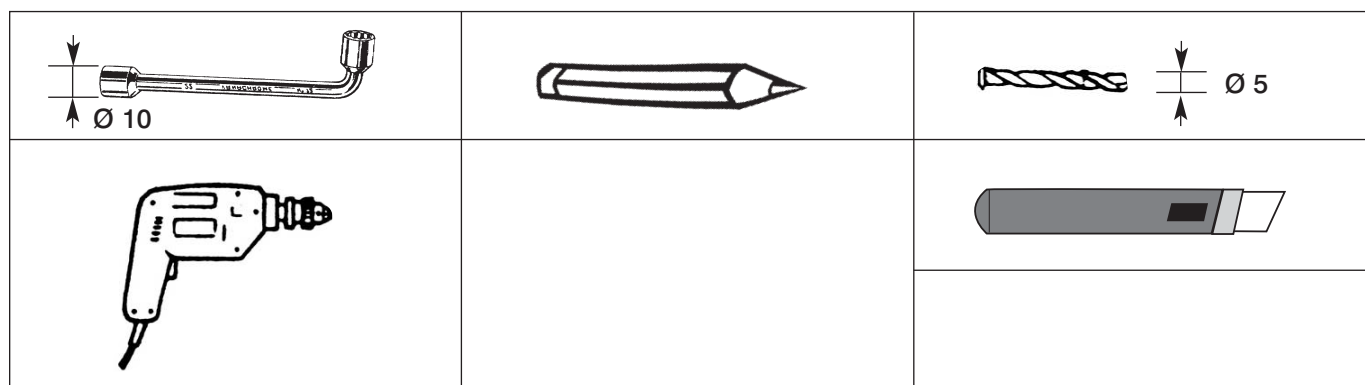

**1** **1-2-3-4 are only applicable in case OE 17" alloy wheel is fitted**

side view

15 mm To be cut out

16 mm

IT THE SAME FOR THE RIGHT MUDFLAP

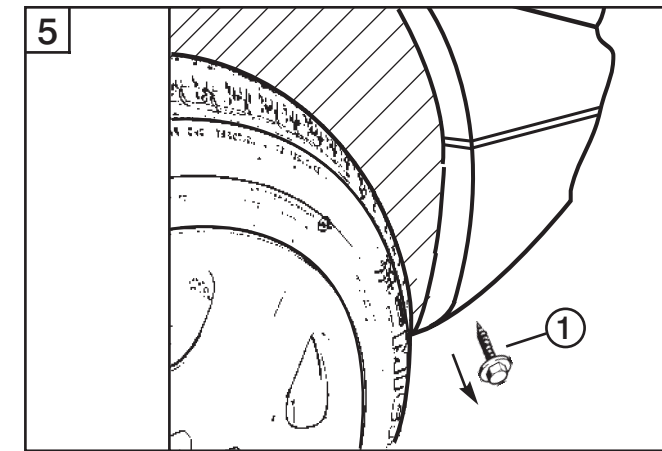
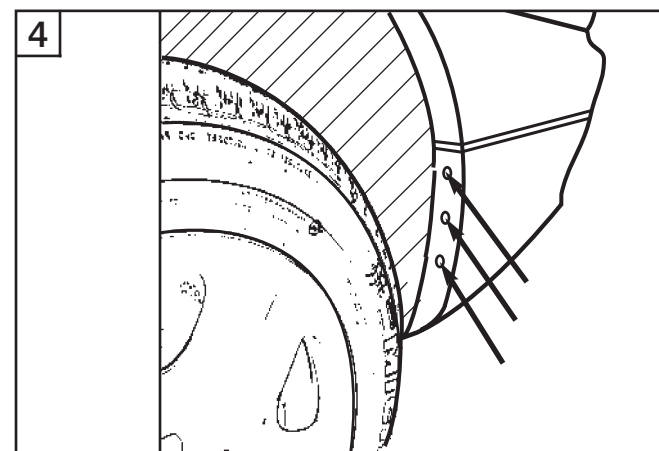
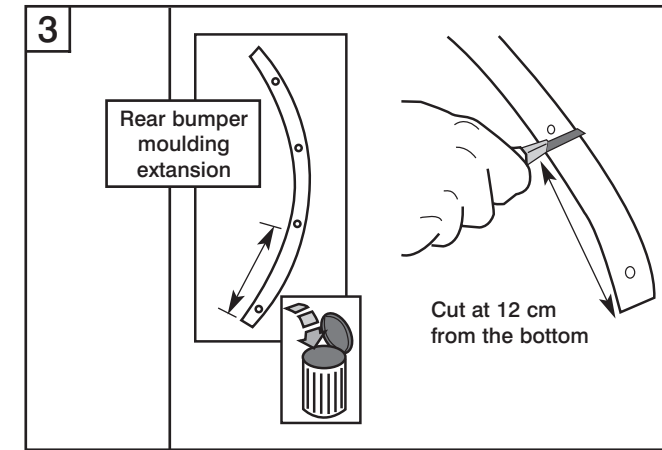
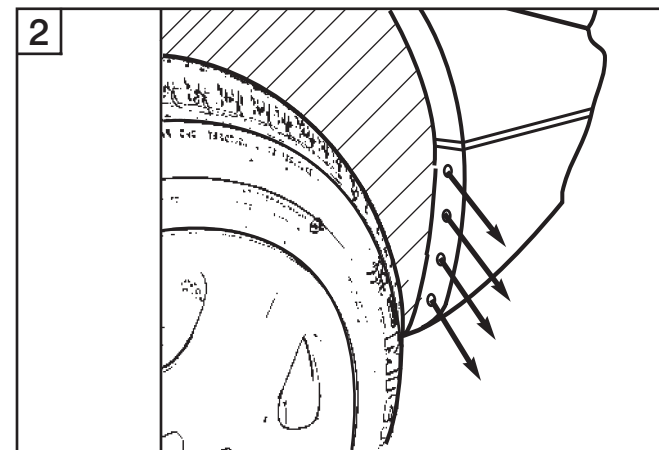

**5** Unscrew the original screw 1  
Original schrauben entfernen 1  
Enlever la vis d'origine 1  
Verwijder de originele schroeven 1

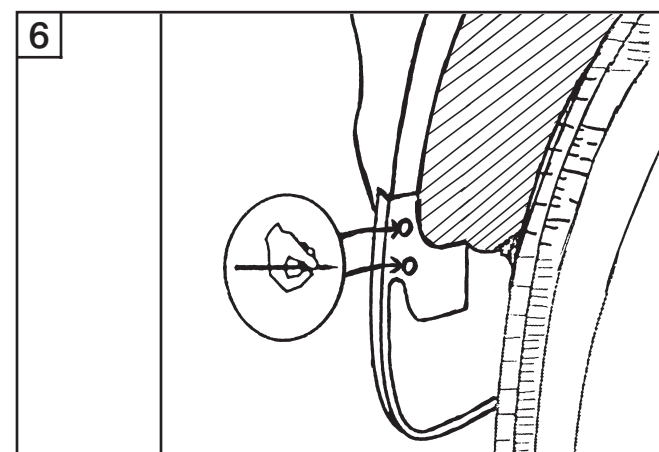

**6** Mark the holes  
Befestigungsbohrungen  
Tracer les 2 trous  
Markeer de te boren gaten

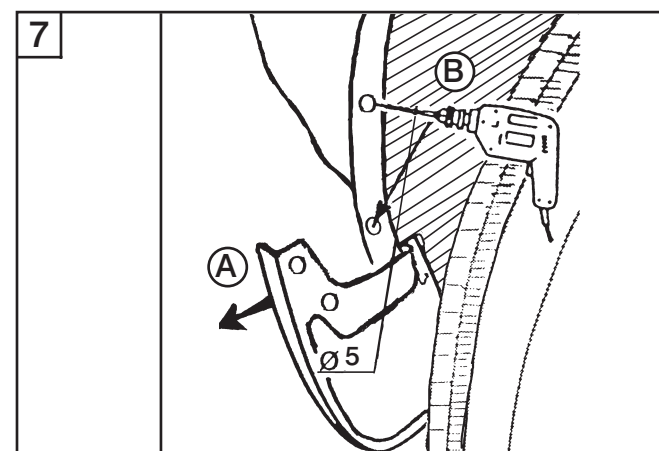

**7** Drill 2 holes of Ø 5  
Die 2 löcher bohren mit einen Ø 5 bohren  
Percer les 2 trous Ø 5  
Boor 2 gaten van Ø 5  
LHS = RHS



Critical operation  
Specifics tools



Operator safety



Check point